

This is the simplest diagram you can construct.  
 The input terminal ISW0 is connected directly to the output terminal OTR0.  
 When you switch on the input, the output goes on; and vice versa.

This diagram has the 3 basic elements of any diagram:  
 Input  
 Output  
 and the function in between

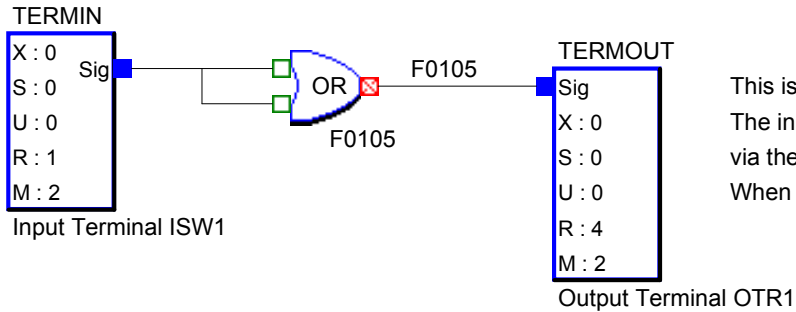

This is the second simplest diagram you can construct.  
 The input terminal ISW1 is connected to the output terminal OTR1  
 via the OR gate whose output is inverted.  
 When you switch on the input, the output goes off; and vice versa.

AmbiLogic does not have a digital inverter: generally it is not needed  
 because digital pins can be inverted on the diagram.  
 However we have a special case with this diagram: although the signal is digital  
 (FALSE/TRUE) it is generated by a function block with an analogue output pin  
 and sensed by a function block with an analogue input pin.  
 There are a dozen ways of implementing an inverter: this is the one we at AmbiLogic use.