

EXDA-01 Expansion Module

Features:

20 Inputs and Outputs:

- 8 Digital Inputs
 - 2 0-1V Analog Inputs
 - 8 Transistor Digital Outputs
 - 2 0-10V Analog Outputs
- #### 3 Medium-Speed (1kHz) counters
- 2 up-count
 - 1 quadrature up/down-count

Low 2W Power Consumption

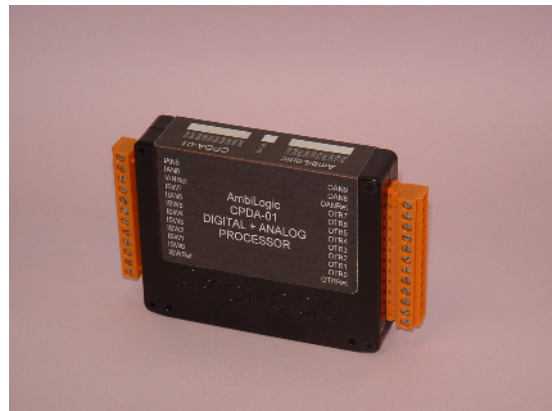

The EXDA-01 is a digital + analogue expansion module which plugs into an AmbiLogic backplane. It offers an identical set of inputs and outputs as the CPDA-01 Processor.

- 8 switch or NPN non-isolated transistor digital inputs
- 2 0 to 1V non-isolated analogue inputs
- 8 NPN transistor non-isolated digital outputs (these can drive relays)
- 2 0 to 10 V non-isolated analogue outputs.

This makes a total of 20 inputs and outputs.

Connections are made via detachable screw terminals.

The EXDA-01 plugs into any numbered slot in any of the AmbiLogic backplanes, and takes its power from the backplane. Its Slot address is picked up automatically from the backplane, and its facilities then become available to diagrams running in the Processor module on the backplane.

AmbiLogic Pty Ltd. ABN 39 110 816 898

Innovation House West, Technology Park, Mawson Lakes, South Australia 5095
+61 8 8260 8110 ph +61 8260 8100 fax info@ambilogic.com.au

EXDA-01 Expansion Module

Connections:

Terminal	Signal	Description	Subslot	Register	Mask
A12	IAN9+	0-1V Analog Input	0	3	0
A11	IAN8+	0-1V Analog Input	0	2	0
A10	IANRet	Analog Return	Return (Gnd) for above signals		
A09	ISW7+	Contact / NPN Input	0	1	128
A08	ISW6+	Contact / NPN Input	0	1	64
A07	ISW5+	Contact / NPN Input	0	1	32
A06	ISW4+	Contact / NPN Input	0	1	16
A05	ISW3+	Contact / NPN Input	0	1	8
A04	ISW2+	Contact / NPN Input	0	1	4
A03	ISW1+	Contact / NPN Input	0	1	2
A02	ISW0+	Contact / NPN Input	0	1	1
A01	ISWRet	Contact / Switch Return	Return (Gnd) for above signals		
C01	OAN9+	0-10 V Analog Output	0	6	0
C02	OAN8+	0-10 V Analog Output	0	5	0
C03	OANRet	Analog Return	Return (Gnd) for above signals		
C04	OTR7+	Transistor Output	0	4	128
C05	OTR6+	Transistor Output	0	4	64
C06	OTR5+	Transistor Output	0	4	32
C07	OTR4+	Transistor Output	0	4	16
C08	OTR3+	Transistor Output	0	4	8
C09	OTR2+	Transistor Output	0	4	4
C10	OTR1+	Transistor Output	0	4	2
C11	OTR0+	Transistor Output	0	4	1
C12	OTRRet	Transistor Output Return	Return (Gnd) for above signals		

Interface to Diagram:

The Slot address for all facilities is taken from the slot into which the EXDA-01 is plugged. In practice this will be 1 upwards.

Subslot 0: Input/Output

- Register 0: Device Identifier: returns hex A502 (42242) for EXDA-01
- Register 1: Contact/NPN Inputs: bit mapped: use mask to select required input
- Register 2: Analog Input 8: returns 0 to 1.00
- Register 3: Analog Input 9: returns 0 to 1.00
- Note that writing (outputting) to the above registers has no effect
- Register 4: Transistor Outputs: bit mapped: use mask to select required output
- Register 5: Analog Output 8: 0 to 10.00 corresponds to output voltage
- Register 6: Analog Output 9: 0 to 10.00 corresponds to output voltage
- Register 7: Count6: medium-speed up counter attached to ISW6
- Register 8: Count7: medium-speed up counter attached to ISW7
- Register 9: CountQ: medium-speed up/down quadrature counter attached to ISW6 and ISW7.

EXDA-01 Expansion Module

Subslot 0: Input/Output (continued)

Register 10:	CountCtrl: Provides reset and hold facilities for the medium-speed counters.
Mask 1:	C6 Reset: Forces Count6 to zero. Once the reset has occurred, the bit itself is reset.
Mask 2:	C6 Hold: Stops Count6 and holds its value. Set and reset via TERMOUT.
Mask 4:	C7 Reset: Forces Count7 to zero. Once the reset has occurred, the bit itself is reset.
Mask 8:	C7 Hold: Stops Count7 and holds its value. Set and reset via TERMOUT.
Mask 16:	CQ Reset: Forces CountQ to zero. Once the reset has occurred, the bit itself is reset.
Mask 32:	CQ Conditional Reset: Forces CountQ to zero when ISW6 and ISW7 are both FALSE (high). Once the reset has occurred, the bit itself is reset. This function is useful where the index signal on a quadrature encoder spans more than one step of the encoder.

Specifications

1. Power Input:
 - +14V 50 mA, +7V 150 mA
 - This is the standard output from the AmbiLogic backplane transformers – so you don't have to worry about it.

2. Contact / NPN Transistor Digital Inputs:
 - Excitation voltage: 6.0 to 9.0 V
 - Sink current: 3.0 to 5.0 mA
 - Maximum Input voltage: -1.0 to +120 V
 - Protection: Zener diode
 - Internal signal: open = FALSE; closed = TRUE;
 - Thresholds: 5.0 V (open); 3.0 V (closed) typical

3. Analogue Inputs:
 - Resolution: 12 bits: 274 μ V per bit
 - Range: 0 to 1.1 V
 - Input resistance: 11.1 k Ω
 - Total errors not exceeding: 4 bits: 1.2 mV: 0.12 % of full range
 - Internal signal: 0 to 1.10

4. Transistor Digital Outputs:
 - Max working voltage: + 33 Vdc
 - Max current: 2.0 A individually: total for all outputs not to exceed 8A
 - Protection: VDR

5. Analogue Outputs:
 - Resolution: 12 bits : 2.4 mV per bit
 - Range: 0 to 10 V
 - Max Output Current: 10 mA
 - Total errors not exceeding: 4 bits : 10 mV : 0.1 % of full range
 - Internal signal: 0.0 to 10.0

EXDA-01 Expansion Module

Specifications (continued)

6. Dimensions:
- | | |
|----------|---|
| Heights: | 83 mm above backplane
97 mm above mounting base when assembled
on to an AmbiLogic backplane on TS35 rail. |
| Width: | 25.0 mm max |
| Depths: | 103 mm over body
125 mm over terminals |
7. Ambient temperature: -10 to +60 °C

Indicators

There are 3 groups of indicators on the top panel of the EXDA-01.

Contact / NPN Input Group:

These are labelled "ISW0" through "ISW7"
The indicators are ON when the input is TRUE, i.e. switched to Return.

Analog Input Group:

These are labelled "IAN8" and "IAN9"
The indicators glow with an intensity proportional to the input voltage.

Status:

This indicator flashes each time the module is interrogated or commanded via the backplane bus. The indicator lights when it recognises a packet addressed to its slot, and goes out when the response has been transmitted.

If this indicator is not flashing, the module is not being addressed. This is not necessarily a fault condition if the processor is not reading the module's inputs or adjusting its outputs. That is to say if the diagram makes no reference to any of the EXDA-01's inputs or outputs, no packets will be sent to the module, and the Status indicator will not flash.

If the outputs alone are referenced, even if the outputs are unchanging, the backplane communications protocol ensures that they are refreshed periodically, so the Status indicator will flash.

Analog Output Group:

These are labelled "OAN9" and "OAN8"
The indicators glow with an intensity proportional to the output voltage.

Transistor Output Group:

These are labelled "OTR7" through "OTR0"
These indicators are ON when the output transistor is ON.

EXDA-01 Expansion Module

Connecting External Devices

1. Switch input ISW0..7

a. Contact Input

Wire the contact between ISW.. and ISWRet.
The input will be TRUE when the contact is closed.

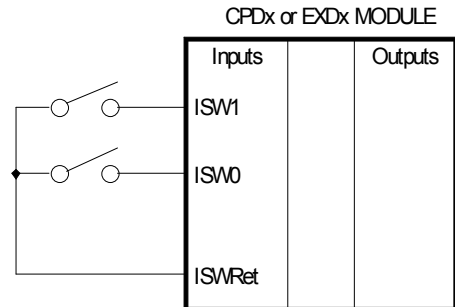

SWTCH INPUTS

NPN Transistor Input

Collector to ISW..
Emitter to ISWRet
The input will be TRUE when the transistor is ON.

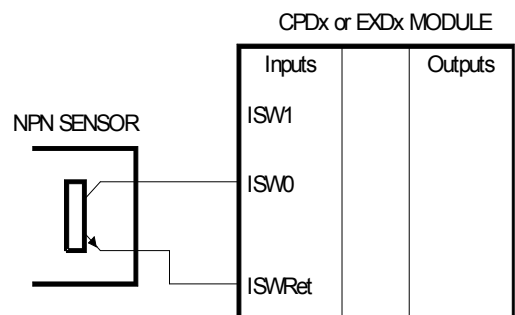

NPN INPUTS

2. Analogue Input IAN8 or IAN9

a. 0 to 1 V input

Positive to IAN8 or 9
Negative to IANRet
Remember that IANRet is not isolated from the PLC ground.

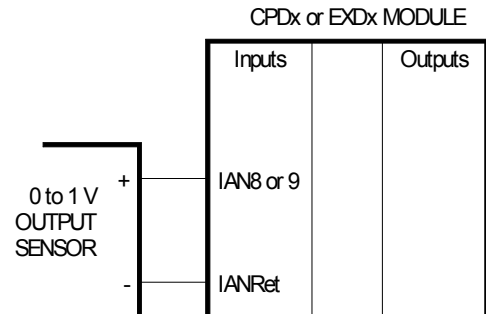

0-1 V ANALOGUE INPUT

b. 0 to 10 V input

Positive to a 100 Kohm 1% resistor
Other side of the resistor to IAN8 or 9
Input resistance of IAN8 and IAN9 is 11.1 Kohm 0.1%.
Negative of the input to IANRet
Remember that IANRet is not isolated from the PLC ground.

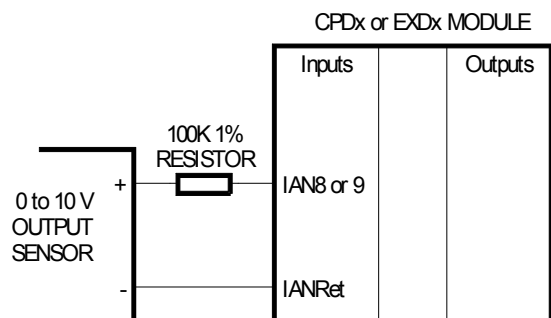

0-10 V ANALOGUE INPUT

EXDA-01 Expansion Module

Analogue Input IAN8 or IAN9 (continued)

- a. 0 to 20 mA or 4 to 20 mA input

Wire a 50 ohm 1% resistor between IAN8 or 9 and IANRet
 Positive input to IAN8 or 9 (and the resistor)
 Negative input to IANRet
 Remember that IANRet is not isolated from the PLC ground, so the PLC must be the lowest device in the loop.
 In the case of 4-20 mA input, 4 mA will input 0.20 to the diagram, and 20 mA will input 1.00 to the diagram.

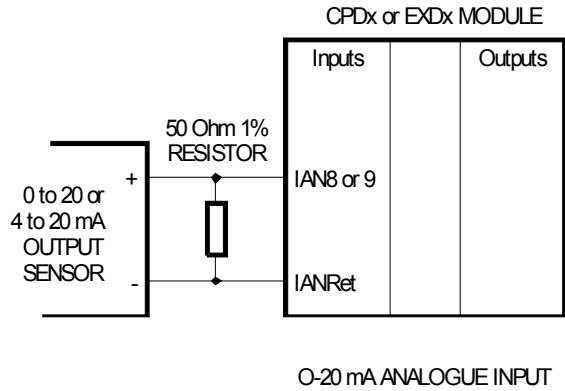

3. Transistor Outputs OTR0..7

- a. Resistive Loads

Negative terminal of the power supply feeding the load to OTRRet.
 Positive terminal of the load to the positive terminal of the power supply.
 Negative terminal of the load to OTR0..7 as required.

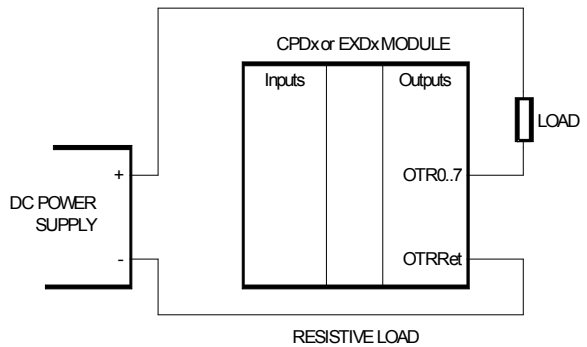

- b. LEDs

Determine whether the LED is fitted with a current limiting circuit. Most LEDs are not, and will need a current limiting resistor wired in series with them.

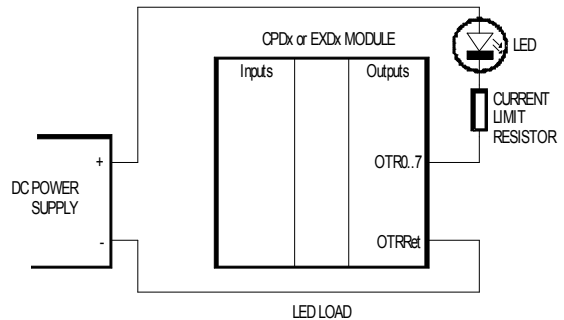

EXDA-01 Expansion Module

Transistor Outputs OTR0..7 (continued)

a. Filament Lamps

The problem with filament lamps is the extremely low resistance when cold, giving rise to a huge current surge when switched on. One approach is to put a current limiting resistor in series with the lamp - the power supply voltage then needs to be greater than the lamp voltage. An alternative approach is to shunt the switching device with a preheat resistor whose value is such that the filament is just at the glow point when the lamp is switched off.

This approach can greatly increase lamp life where lamps are switched on and off frequently, e.g. where a lamp is flashed as a warning.

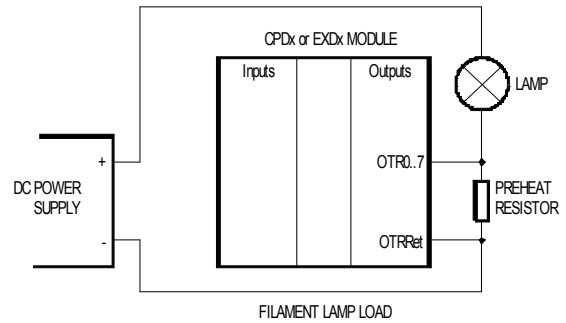

b. Relays and Solenoids

Inductive loads such as relays and solenoids normally need arrestor diodes across them to protect the switching element. AmbiLogic transistor outputs have VDR protection so that the diodes are not strictly necessary. Fitting the diodes can reduce the voltage spikes associated with turning inductive loads off however.

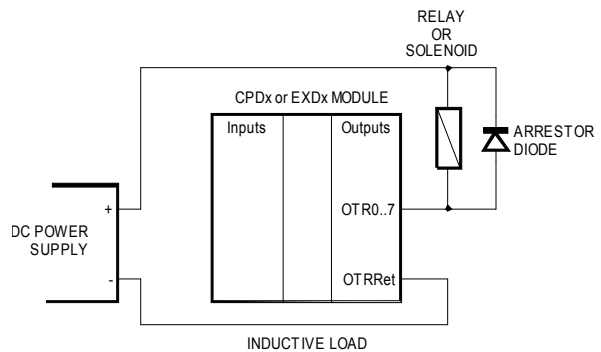

EXDA-01 Expansion Module

4. Analogue Outputs OAN 8 and 9

a. Voltage Output (0 to 10 V)

The voltage outputs have an internal resistance of 100 ohms. If the load has a significant resistance, the output voltage will be less than expected. Most 0-to-10 V devices have input resistances greater than 100 Kohms, so the loading error will be less than 0.1% .

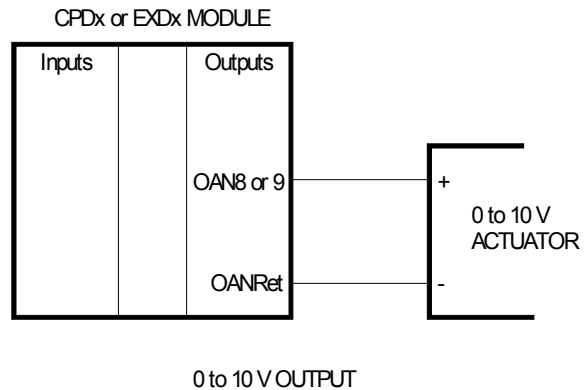

b. Current Output (0 to 20 mA)

The total circuit resistance including loads, the internal resistance of 100 ohms, and the padding resistor needs to total 500 ohms.

An output value of 10.0 from the diagram will produce 20 mA. An output value of 2.0 will produce 4 mA.

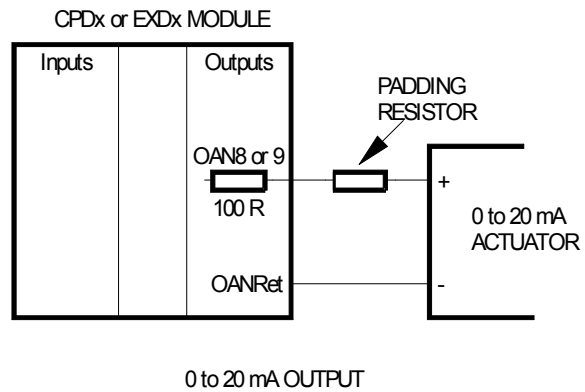

WARNING SAFETY-CRITICAL SYSTEMS

A Safety-Critical system is a system whose failure or malfunction could cause death, significant injury or loss of property.

AmbiLogic products contain electronic and software content, both of which carry a remote but real possibility of failure. AMBILOGIC DOES NOT WARRANT OR REPRESENT THAT ITS PRODUCTS ARE INFALLIBLE.

It is the therefore responsibility of the designer of any safety-critical system which incorporates AmbiLogic products to ensure that:-

1. The system is designed so that any failure of an AmbiLogic component will not cause death, injury or loss of property.
2. The system incorporates independent monitoring means which detect the failure of any of the electronic control elements.
3. The system has alternative and independent means of control which enable it to be controlled and shut down in an orderly manner.
4. Any other industry-specific safety requirements are fully implemented.